

REV.	DESCRIPTION	DRAWN	CHECKED	APPROVED
A	NEW RELEASE	YCH 08/18/07		

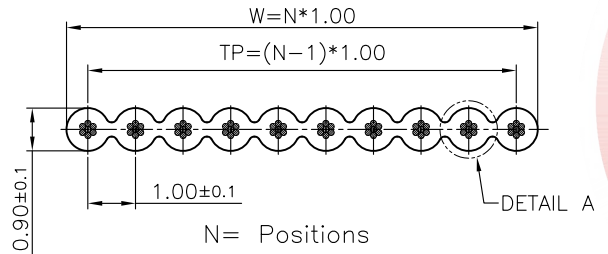

- NOTES:
- Insulation material: PVC
Color: Grey
 - SPECIFICATION
 - Rating: 300V
 - Conductor Size: 28AWG Or 30AWG
 - Insulation resistance: 100MΩ/km min.
 - APPLICATION
 - Internal wiring of computers, electronic exchanges, measurement control devices, business machines, communication devices, and other electronic equipment.

4. Product Number Code
DS1057-01 - X X X X X - X

- Packing Specifications
 - 30.5: 30.5m/reel
 - 76.5: 76.5m/reel
- Edge mark
 - R: Red mark
 - F: Flower mark
- Wire diameter
 - 1: $\phi 0.100$ (30AWG)
 - 2: $\phi 0.127$ (28AWG)
- Wire AWG
 - 28: 28AWG
 - 30: 30AWG
- Cable color
 - A: Gray
- No. Of positions
 - 10: 10pin
 - 64: 64pin

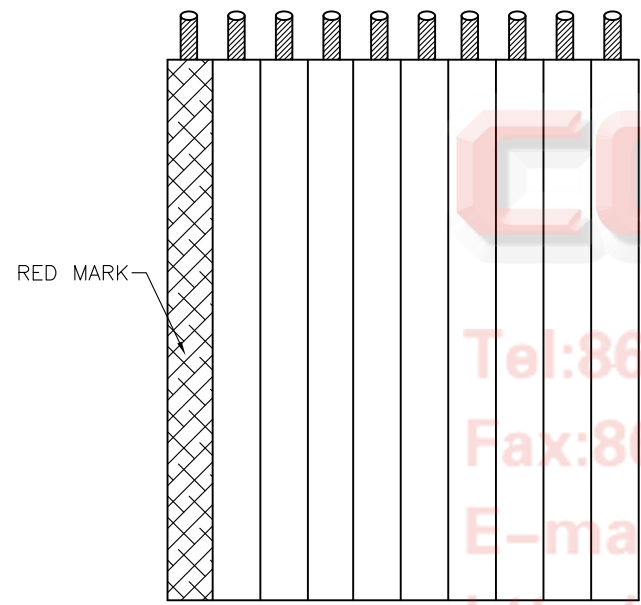

Number	Dimensions			Max. conductor resistance DC 20°C Ω/m
	TP(mm)	W(mm)	Tolerance	
10	9.00	10.00	±0.30	$\phi 0.100 < 0.397$
14	13.00	14.00	±0.30	
16	15.00	16.00	±0.30	
20	19.00	20.00	±0.30	
24	23.00	24.00	±0.30	
26	25.00	26.00	±0.30	
30	29.00	30.00	±0.30	
34	33.00	34.00	±0.40	
40	39.00	40.00	±0.40	
50	49.00	50.00	±0.40	
60	59.00	60.00	±0.40	
64	63.00	64.00	±0.40	

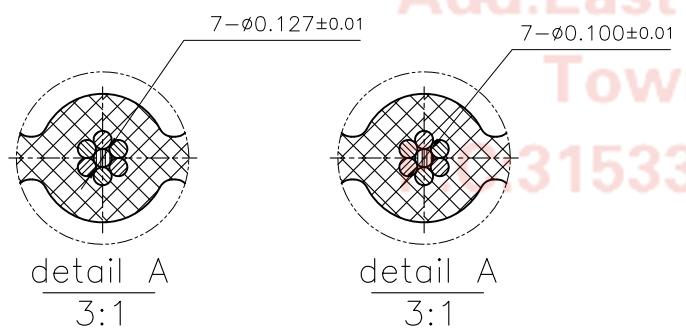

GENERAL TOLERANCE		ANGLE TOLERANCE		PROJECTION		TITLE	UL 2651 PITCH 1.00mm FLAT CABLE	
X.	±0.60	X.	±5°	UNITS	mm	SHEET SIZE	A4	
.X	±0.38	.X	±3°	SHEET SIZE	A4	SERIES	DS1057-01	
.XX	±0.25	.XX	±2°	晨翔电子有限公司 CONNFLY CONNFLY ELECTRONIC CO. LTD				
DRAWING TYPE		CUSTOMER						
SCALE	1:1	SHEET	1 OF 1					
DRAWING NO.		C-DS1057-01-XXXXX						