



SGM3759

38V High Efficiency, Boost WLED Driver with Strobe Interface for Flash Mode

GENERAL DESCRIPTION

With a 40V rated integrated switch FET, the SGM3759 is a boost converter that drives LEDs in series. The boost converter has a 40V, 3A internal MOSFET; thus it can drive single or parallel LED strings for small to large size panel backlighting. And it is quite suitable for smart phone image capture using display device as a flash mode light source, as it can output up to 200mA current at 30V for 320ms when the strobe signal is active.

The backlight mode default white LED current is set with the external sense resistor, R_{SET} , and the feedback voltage is regulated to 200mV, as shown in the Typical Application. During the operation, the LED current can be controlled by a pulse width modulation (PWM) signal applied to the CTRL pin, through which the duty cycle determines the feedback reference voltage. The SGM3759 does not burst the LED current; therefore, it does not generate audible noises on the output capacitor. For maximum protection, the device features integrated open LED protection that disables the SGM3759 to prevent the output voltage from exceeding the IC absolute maximum voltage ratings during open LED conditions.

When the device is working, if the STROBE pin is pulled up, it will turn on flash mode within 100 μ s. And the feedback voltage is regulated to 5 \times of the backlight mode that determined by the PWM signal duty cycle. And it will turn to backlight mode within 100 μ s when the STROBE pin is pulled down or the strobe signal keeps high over the 320ms timer.

The SGM3759 is available in Green TSOT-23-6 package. It operates over an ambient temperature range of -40 $^{\circ}$ C to +85 $^{\circ}$ C.

FEATURES

- Input Voltage Range: 2.7V to 5.5V
- Integrated 3A/40V MOSFET
- Output Voltage Up to 38V (OVP)
- Output Current Up to 200mA @ 30V
- Accumulated 320ms Flash Timer Control
- 1.2MHz Switching Frequency
- PWM Dimming Control Interfaces
- PWM Frequency: 20kHz ~ 100kHz
- Strobe Interface for Image Capture Mode
- Up to 87% Efficiency for 7S2P LEDs
- Up to 92% Efficiency for 3S20P LEDs
- Dimming Stable in 1:500 Range
- 200mV Feedback Voltage in Backlight Mode
- 1000mV Feedback Voltage in Flash Mode
- Flash Mode Under-Voltage Lockout
- Built-In Soft-Start Function
- Over-Voltage Protection
- Built-In WLED Open/Short Protection
- PFM Mode at Light Load
- Thermal Shutdown
- -40 $^{\circ}$ C to +85 $^{\circ}$ C Operating Temperature Range
- Available in Green TSOT-23-6 Package

APPLICATIONS

Smart Phones
PDAs, Handheld Computers
Backlight for Small and Media Form-Factor LCD Displays
with Single-Cell Battery Input

PACKAGE/ORDERING INFORMATION

MODEL	PACKAGE DESCRIPTION	SPECIFIED TEMPERATURE RANGE	ORDERING NUMBER	PACKAGE MARKING	PACKING OPTION
SGM3759	TSOT-23-6	-40°C to +85°C	SGM3759YTN6G/TR	M17XX	Tape and Reel, 3000

NOTE: XX = Date Code.

Green (RoHS & HSF): SG Micro Corp defines "Green" to mean Pb-Free (RoHS compatible) and free of halogen substances. If you have additional comments or questions, please contact your SGMICRO representative directly.

MARKING INFORMATION

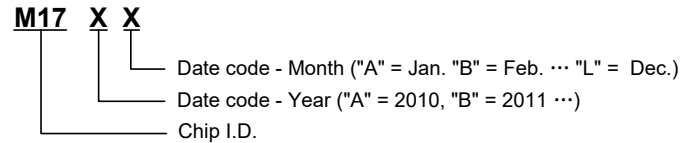

For example: M17HA (2017, January)

ABSOLUTE MAXIMUM RATINGS

- Voltages on VIN, CTRL, STROBE, FB -0.3V to 6V
- Package Thermal Resistance
- TSOT-23-6, θ_{JA} 190°C/W
- Voltage on SW -0.3V to 40V
- Junction Temperature +150°C
- Storage Temperature Range -65°C to +150°C
- Lead Temperature (Soldering, 10s) +260°C
- ESD Susceptibility
- HBM 3000V
- MM 200V
- CDM 1000V

RECOMMENDED OPERATING CONDITIONS

- Input Voltage Range 2.7V to 5.5V
- Output Voltage Range V_{IN} to 38V
- Inductor 4.7 μ H to 22 μ H
- Input Capacitor 1 μ F (MIN)
- Output Capacitor 1 μ F to 10 μ F
- Operating Temperature Range -40°C to +85°C

OVERSTRESS CAUTION

Stresses beyond those listed may cause permanent damage to the device. Functional operation of the device at these or any other conditions beyond those indicated in the operational section of the specification is not implied. Exposure to absolute maximum rating conditions for extended periods may affect reliability.

ESD SENSITIVITY CAUTION

This integrated circuit can be damaged by ESD if you don't pay attention to ESD protection. SGMICRO recommends that all integrated circuits be handled with appropriate precautions. Failure to observe proper handling and installation procedures can cause damage. ESD damage can range from subtle performance degradation to complete device failure. Precision integrated circuits may be more susceptible to damage because very small parametric changes could cause the device not to meet its published specifications.

DISCLAIMER

SG Micro Corp reserves the right to make any change in circuit design, specification or other related things if necessary without notice at any time.

PIN CONFIGURATION

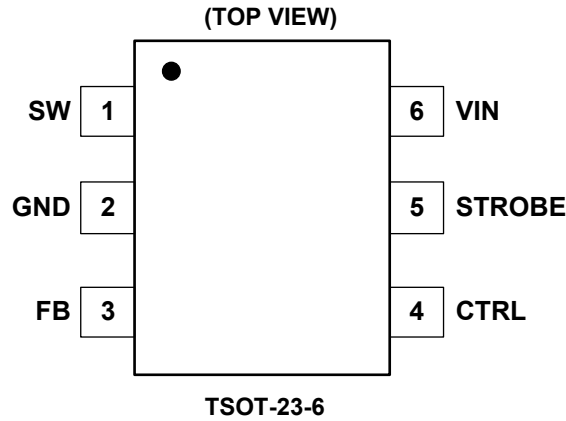

PIN DESCRIPTION

PIN	NAME	I/O	FUNCTION
1	SW	I	Switching Node of the IC. Connect the inductor between VIN and SW. This pin is also used to sense the output voltage for open LED protection.
2	GND	O	Ground.
3	FB	I	Feedback Pin for Current. Connect the sense resistor from FB to GND.
4	CTRL	I	Control Pin of the Boost Regulator. It is a multi-functional pin which can be used for enable and PWM dimming control.
5	STROBE	I	Strobe Signal Input. This pin synchronizes the flash pulse to the image capture. In most cases, this signal comes directly from the image sensor.
6	VIN	I	Input Supply Pin. Connect VIN to a supply voltage between 2.7V and 5.5V.

NOTE: I: input; O: output.

TYPICAL APPLICATION

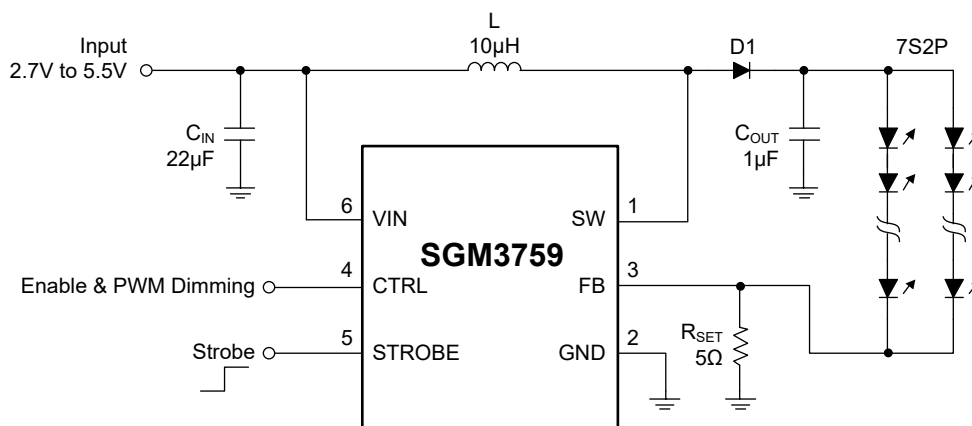

Figure 1. Typical Application

ELECTRICAL CHARACTERISTICS

(V_{IN} = 3.6V, CTRL = V_{IN}, C_{IN} = 22μF, Full = -40°C to +85°C, typical values are at T_A = +25°C, unless otherwise noted.)

PARAMETER	SYMBOL	CONDITIONS	TEMP	MIN	TYP	MAX	UNITS
POWER SUPPLY							
Input Voltage Range	V _{IN}		Full	2.7		5.5	V
Under-Voltage Lockout Threshold	UVLO	V _{IN} falling	+25°C		2.2		V
		V _{IN} rising	+25°C		2.3	2.5	V
UVLO Hysteresis	V _{HYS}		+25°C		100		mV
Operating Quiescent Current into V _{IN}	I _Q	V _{FB} = 300mV, no switching	+25°C		0.2	0.35	mA
Shutdown Current	I _{SD}	CTRL = GND	+25°C			1	μA
BOOST CONVERTER							
Backlight Mode Feedback Regulation Voltage	V _{FB(BL)}	PWM duty cycle 100%	+25°C	195.5	200	206.3	mV
		PWM duty cycle 10%	+25°C	18	20	22	mV
		PWM duty cycle 1%	+25°C	1.4	2.2	3	mV
		PWM duty cycle 0.2%	+25°C		0.65		mV
Flash Mode Feedback Regulation Voltage	V _{FB(FL)}	PWM duty cycle 100%	+25°C	950	1000	1050	mV
		PWM duty cycle 67%	+25°C	630	670	710	mV
		PWM duty cycle 33%	+25°C	300	330	360	mV
FB Pin Bias Current	I _{FB}	V _{FB} = 100mV	+25°C		0.6	1	μA
V _{REF} Filter Time Constant	t _{REF}		+25°C		0.1		ms
N-Channel MOSFET On-Resistance	R _{DS(ON)}		+25°C		0.2	0.3	Ω
Switching Frequency	f _{SW}		Full	0.9	1.2	1.35	MHz
Switching MOSFET Current Limit for Backlight Mode	I _{LIMBL}		+25°C	1.15	1.5	1.85	A
Switching MOSFET Current Limit for Flash Mode	I _{LIMFL}		+25°C		3		A
Output Voltage Over-Voltage Threshold	V _{OVP_SW}		Full	36	38	39.5	V
CONTROL							
CTRL Logic High Voltage	V _{CTRLH}		Full	1.6			V
CTRL Logic Low Voltage	V _{CTRLL}		Full			0.4	V
CTRL Pin internal Pull-Down Resistor	R _{CTRLPD}		+25°C		580		kΩ
CTRL Logic High Time to Backlight Mode	t _{RP1}		+25°C		6		ms
CTRL Logic Low Time to Shutdown	t _{SD1}	CTRL high to low	+25°C	2.5			ms
STROBE Logic High Voltage	V _{STROBEH}		Full	1.6			V
STROBE Logic Low Voltage	V _{STROBEL}		Full			0.4	V
STROBE Pin internal Pull-Down Resistor	R _{STROBEPD}		+25°C		180		kΩ
STROBE Logic High Time to Flash Mode	t _{RP2}		+25°C		50		μs
STROBE Logic Low Time to Backlight Mode	t _{SD2}		+25°C		50		μs
Flash Mode Under-Voltage Lockout Threshold	UVLO _{FL}		+25°C	3.2	3.3	3.45	V
Flash Mode UVLO Hysteresis	V _{HYSFL}		+25°C		100		mV
Flash Mode Timer	t _p		+25°C	280	320	380	ms
PWM Dimming Frequency Range	DFR		+25°C	20		100	kHz
Minimum PWM On-Time			+25°C	40			ns
PWM Duty Cycle Changing Time to Output	DCCTO	Duty cycle from 100% to 50%	+25°C		2		ms
Stable Dimming Range	DR		+25°C	0.2		100	%
THERMAL SHUTDOWN							
Thermal Shutdown Threshold	T _{SHUTDOWN}				160		°C
Thermal Shutdown Hysteresis	T _{HYS}				20		°C

RECOMMENDED COMPONENTS OF TEST CIRCUITS

COMPONENT		COMPONENT	
INDUCTOR	10μH/ETQP3M100KVP	CAPACITOR	1μF/C2012X7R1H105JT
DIODE	PMEG4030ER		22μF/C2012X7R1H226JT

TYPICAL PERFORMANCE CHARACTERISTICS

T_A = +25°C, L = 10μH, C_{IN} = 22μF, C_{OUT} = 1μF, unless otherwise noted.

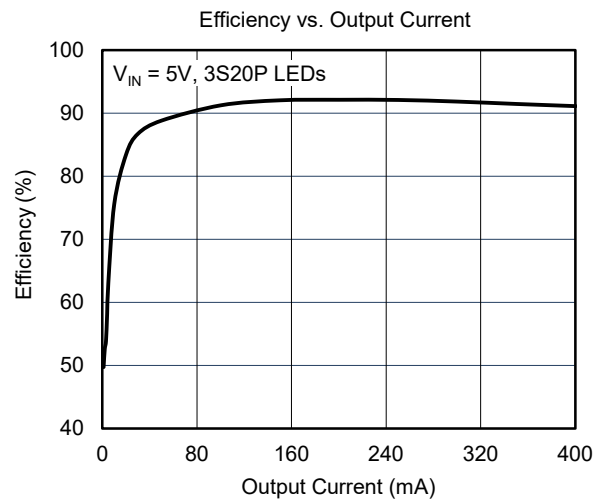
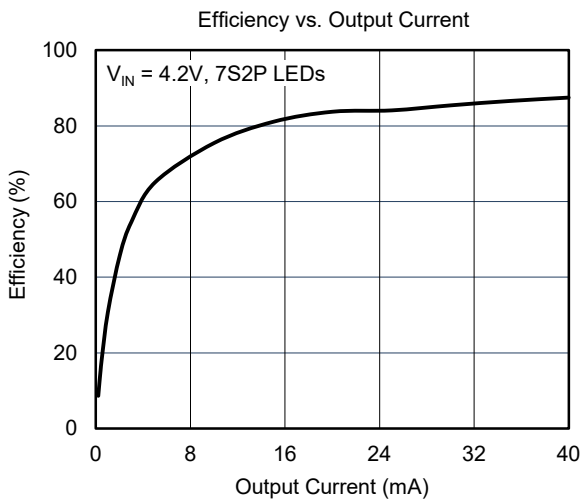
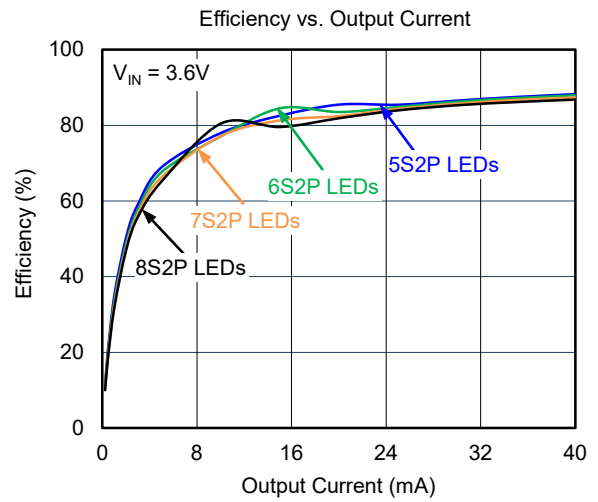
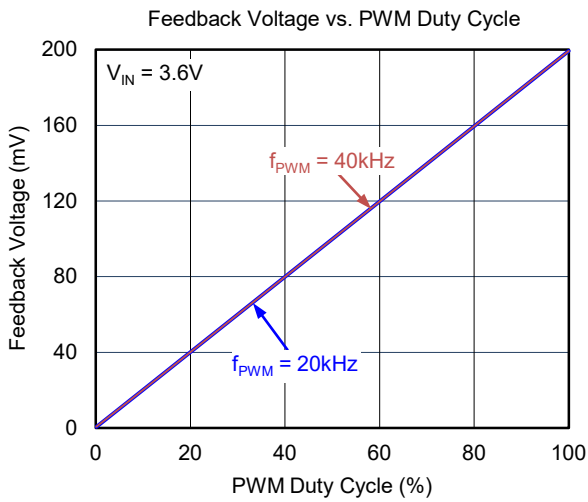

TYPICAL PERFORMANCE CHARACTERISTICS (continued)

T_A = +25°C, L = 10µH, C_{IN} = 22µF, C_{OUT} = 1µF, unless otherwise noted.

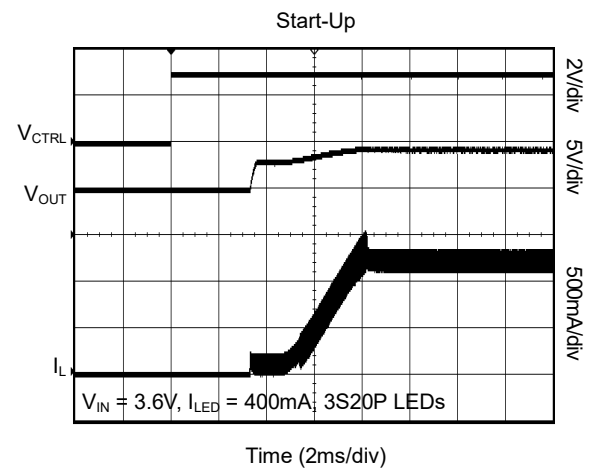
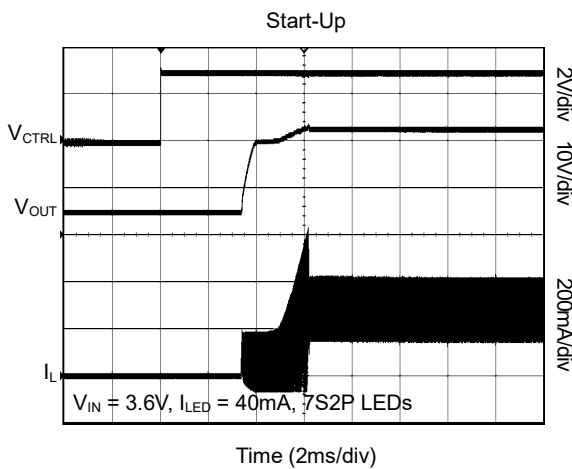
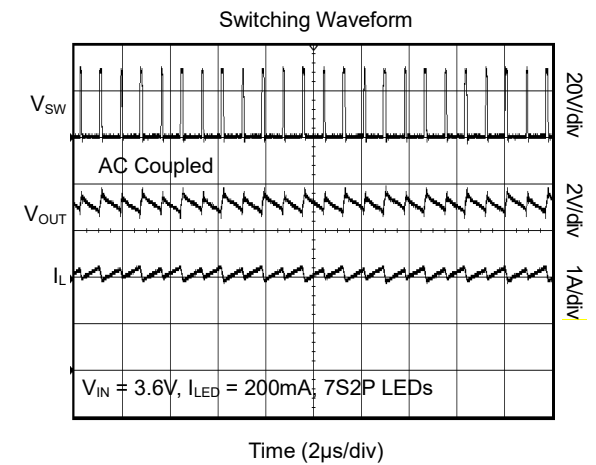
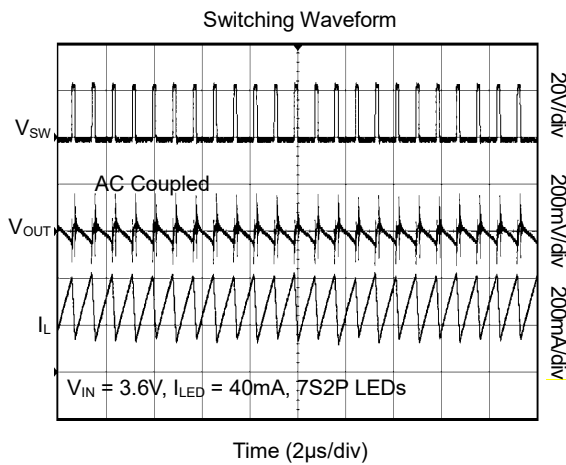
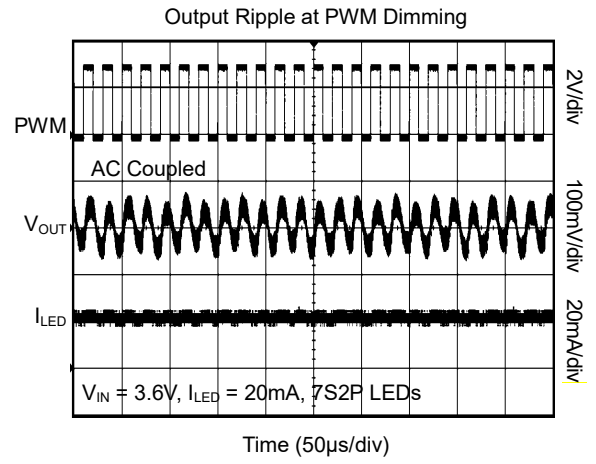
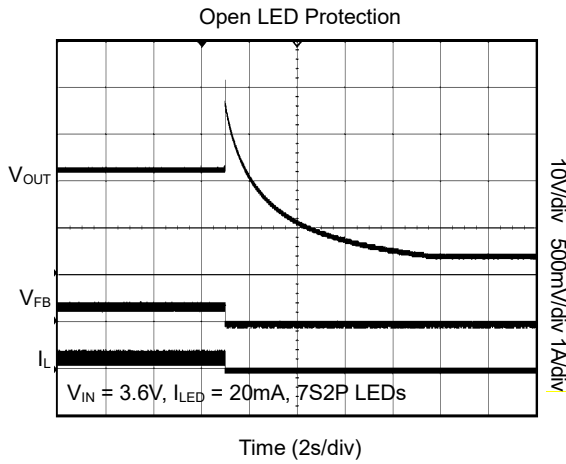

TYPICAL PERFORMANCE CHARACTERISTICS (continued)

T_A = +25°C, L = 10μH, C_{IN} = 22μF, C_{OUT} = 1μF, unless otherwise noted.

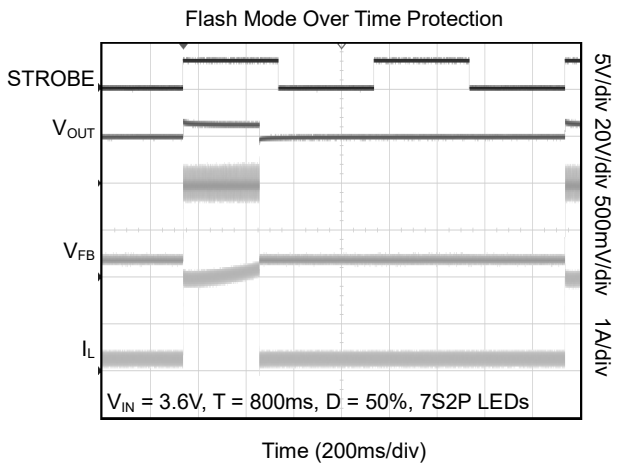
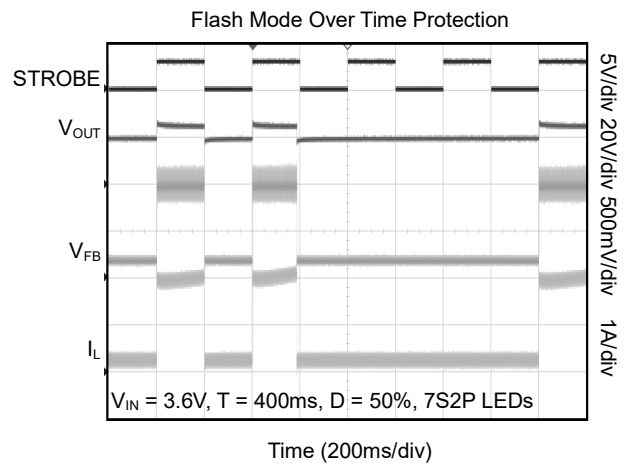
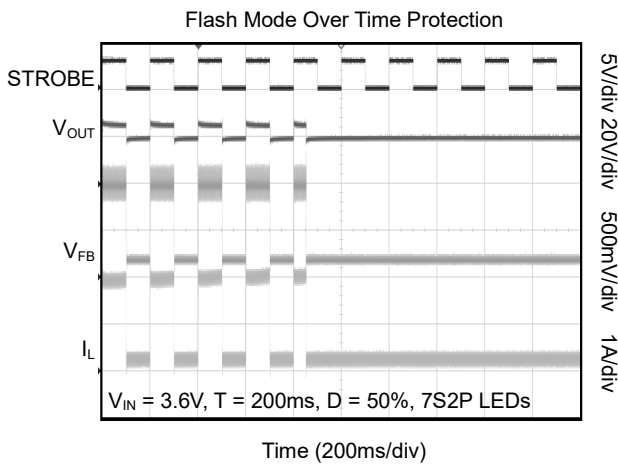
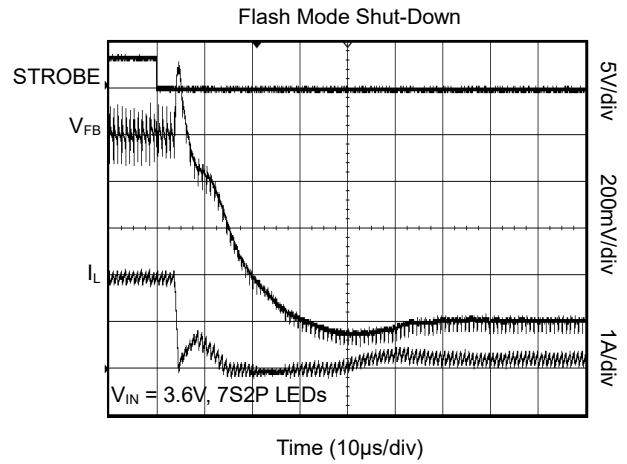
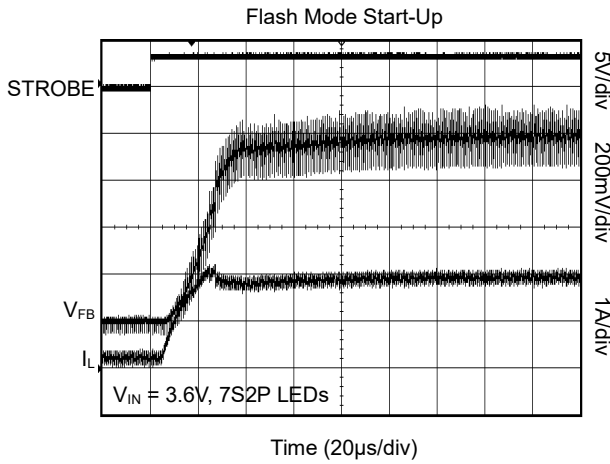

FUNCTIONAL BLOCK DIAGRAM

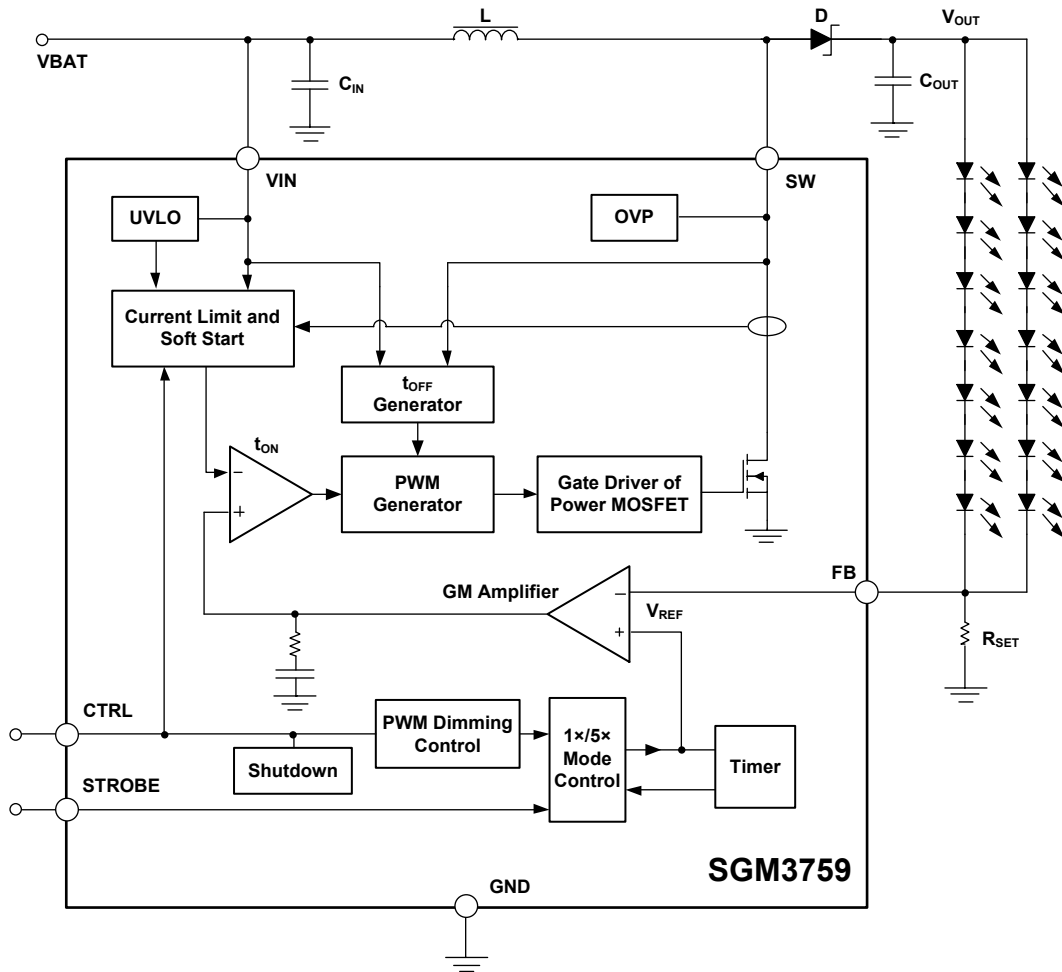

Figure 2. SGM3759 Block Diagram

TIMING DIAGRAM

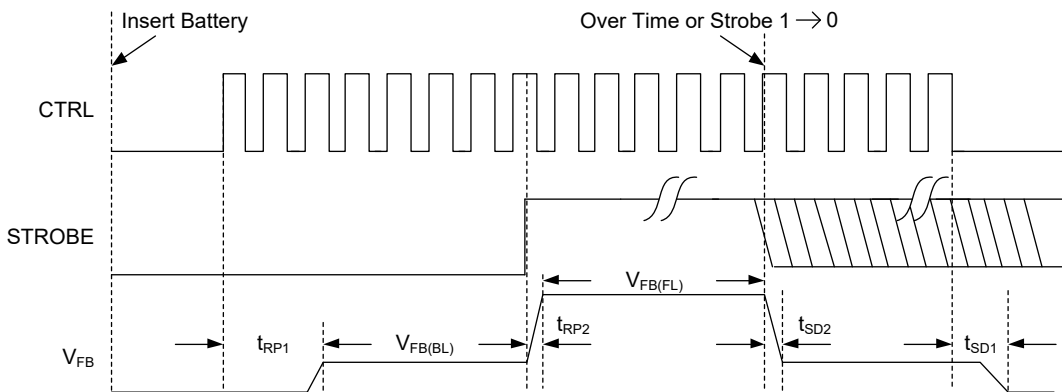

Figure 3. SGM3759 Interface Timing Diagram

DETAILED DESCRIPTION

The SGM3759 is a high efficiency, high output voltage boost converter in small package size. The device integrates 40V switch FET and is designed for output voltage up to 38V with a peak switch current limit of 3A. Its large driving capability can drive single or parallel LED strings for small to large size panel backlighting, and can drive LED string(s) in flash mode specially.

The SGM3759 operates in a current mode scheme with quasi-constant frequency. It is internally compensated for maximum flexibility and stability. The switching frequency is 1.2MHz, and the minimum input voltage is 2.7V. During the on-time, the current rises into the inductor. When the current reaches the threshold value set by the internal GM amplifier, the power switch MOSFET is turned off. The polarity of the inductor changes and forward biases the Schottky diode which lets the current flow towards the output of the boost converter.

The SGM3759 topology has also the benefits of providing very good load and line regulations, and excellent line and load transient responses.

The feedback loop regulates the FB pin to a low reference voltage (200mV typical), reducing the power dissipation in the current sense resistor.

Soft Start-Up

Soft-start circuitry is integrated into the IC to avoid high inrush current spike during start-up. After the device is enabled, the GM amplifier output voltage ramps up very slowly, which ensures that the output voltage rises slowly to ensure the smooth start-up and minimize the inrush current.

Open LED Protection

Open LED protection circuitry prevents IC damage as the result of white LED disconnection. The SGM3759 monitors the voltage at the SW pin during each switching cycle. The circuitry turns off the switch FET

and shuts down the IC when the following condition persists for 8 switching cycles: the SW voltage exceeds the V_{OVP} threshold. As the result, the output voltage falls to the level of the input supply. The device remains in shutdown mode until it is enabled by toggling the CTRL pin.

Shutdown

The SGM3759 enters shutdown mode when the CTRL voltage is logic low for more than 2.5ms. Although the internal switch FET does not switch in shutdown, there is still a DC current path between the input and the LEDs through the inductor and Schottky diode. The minimum forward voltage of the LED array must exceed the maximum input voltage to ensure that the LEDs remain off in shutdown.

Programming LED Current

In backlight mode, the FB voltage is regulated by a low 200mV reference voltage. And in flash mode, it changes to 1000mV. The LED current is programmed externally by a current-sense resistor in series with the LED string(s). The value of the R_{SET} is calculated by Equation 1:

$$I_{LED} = \frac{V_{FB}}{R_{SET}} \quad (1)$$

where:

I_{LED} = total output current of LED string(s)

V_{FB} = regulated voltage of FB pin

R_{SET} = current sense resistor

The output current tolerance depends on the FB accuracy and the current sensor resistor accuracy.

DETAILED DESCRIPTION (continued)**Backlight Mode LED Brightness Dimming**

The SGM3759 receives PWM dimming signal at CTRL pin to control the total output current. When the CTRL pin is constantly high, the FB voltage is regulated to 200mV typically. When the duty cycle of the input PWM signal is low, the regulation voltage at FB pin is reduced, and the total output current is reduced; therefore, it achieves LED brightness dimming. The relationship between the duty cycle and FB regulation voltage is given by Equation 2:

$$V_{FB(BL)} = \text{Duty} \times 200\text{mV} \quad (2)$$

where:

$V_{FB(BL)}$ = FB voltage of backlight mode

Duty = duty cycle of the PWM signal

200mV = internal reference voltage

Thus, the user can easily control the WLED brightness by controlling the duty cycle of the PWM signal. The PWM frequency is in the range from 20kHz to 100kHz, and the recommended minimum PWM duty cycle is 0.2% for reliable dimming.

As shown in Figure 4, the IC chops up the internal 200mV reference voltage V_{BG} at the duty cycle of the PWM signal. The pulse signal is then filtered by an internal low pass filter. The output of the filter is connected to the GM amplifier as the reference voltage for the FB pin regulation. Therefore, although a PWM signal is used for brightness dimming, only the WLED DC current is modulated, which is often referred as analog dimming. This eliminates the audible noise which often occurs when the LED current is pulsed in replica of the frequency and duty cycle of PWM control. Unlike other methods which filter the PWM signal for analog dimming, SGM3759 regulation voltage is independent of the PWM logic voltage level which often has large variations.

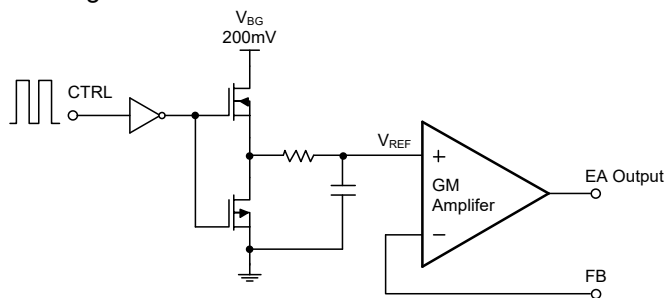

Figure 4. Programmable FB Voltage Using PWM Signal

Under-Voltage Lockout

An under-voltage lockout prevents operation of the device at input voltages below typical 2.2V. When the input voltage is below the under-voltage threshold, the device is shut down, and the internal switch FET is turned off. If the input voltage rises by under-voltage lockout hysteresis, the IC restarts.

Thermal Shutdown

If the typical junction temperature of 160°C is exceeded, an internal thermal shutdown turns off the device. The device is released from shutdown automatically when the junction temperature decreases by 20°C.

Operation with CTRL

The enable rising edge threshold voltage is 1.6V and the falling edge threshold voltage is 0.4V. With the CTRL terminal held below the falling edge threshold voltage the device is disabled and switching is inhibited. The IC quiescent current is reduced in this state. When input voltage is above the UVLO threshold, and the CTRL terminal voltage is increased above the rising edge threshold, the device becomes active. Switching enables and the soft-start sequence initiates.

DETAILED DESCRIPTION (continued)

Flash Mode LED Brightness Dimming

As shown in Figure 3, when the device is working in backlight mode and the STROBE is pulled up from low to high, the reference voltage V_{BG} shown in Figure 4 will change to 1000mV. And the device will turn to flash mode within t_{RP2} . The relationship between the duty cycle and FB regulation voltage is given by Equation 3:

$$V_{FB(FL)} = \text{Duty} \times 1000\text{mV} \quad (3)$$

where:

$V_{FB(BL)}$ = FB voltage of flash mode

Duty = duty cycle of the PWM signal

1000mV = flash mode internal reference voltage

The device monitors the input voltage. If the input voltage is below 3.3V, the V_{BG} will stay at 200mV, regardless of whether the strobe signal is high or low.

Flash Mode Over Time Protection

As shown in Figure 5, after the SGM3759 is enabled by CTRL, the first rising edge of STROBE can trigger the SGM3759 into flash mode. Then the strobe signal is monitored by an internal cumulative timer. The timer increases with all of the HIGH pulses and decreases with 1/3 of the LOW pulses. Once the timer reaches 320ms, it turns the device to backlight mode automatically to protect the LEDs from damage due to

overheat. Then the device will remain in the backlight mode for 960ms (typical), for the die temperature to be lowered enough. If the CTRL pin turns to low, the device will change to standby mode within t_{SD1} , while the timer keeps cumulating till zero, and then the device will be shut down.

The relationship between the timer and STROBE is given by Equation 4:

$$T_C = T_1 - t_1/3 + T_2 - t_2/3 + \dots + T_{n-1} - t_{n-1}/3 + \dots \quad (4)$$

where:

T_C = cumulative time of timer

T_n = high pulse time of STROBE

t_n = low pulse time of STROBE

PWM Duty Cycle Changing

In order to avoid the device output current blinks when the PWM signal chops, there is a filter in the PWM signal path, and this affects the time from the duty cycle changes to output current becomes stable. The typical time is 2ms.

As a result, if you want to use the flash mode by strobe signal and the output current needs a different PWM duty cycle, you should change the duty cycle at least 10ms before the rising edge of the strobe signal.

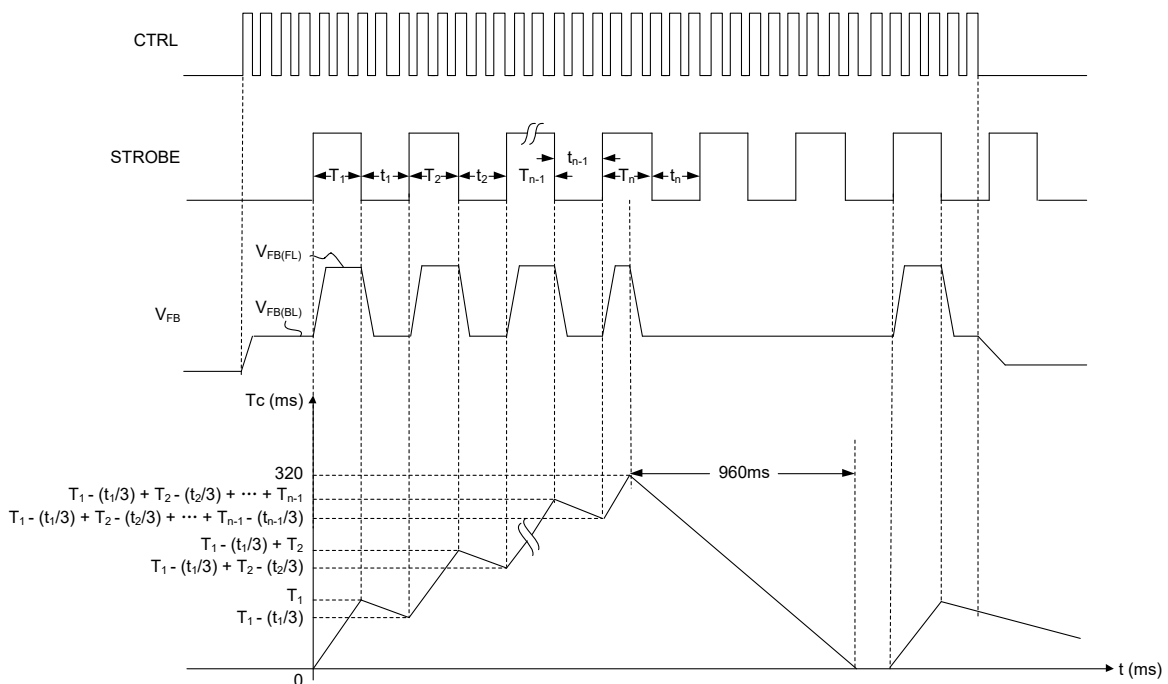

Figure 5. Timing Diagram

APPLICATION INFORMATION

The SGM3759 device is a step-up DC/DC converter which can drive single or parallel LED strings for small to large size panel backlighting.

Design Requirements

For this design example, use the parameters listed in Table 1 as the input parameters.

Table 1. Design Parameters

DESIGN PARAMETER	EXAMPLE VALUE
Input Voltage Range	2.7V to 5.5V
Output, LED Number in A String	7
Output, LED String Number	2
Output, LED Current per String	20mA

Inductor Selection

The selection of the inductor affects power efficiency, steady state operation as well as transient behavior and loop stability. These factors make it the most important component in power regulator design. There are three important inductor specifications, inductor value, DC resistance and saturation current. Considering inductor value alone is not enough. The inductor value determines the inductor ripple current. Choose an inductor that can handle the necessary peak current without saturating. Follow Equation 5 to Equation 6 to calculate the inductor's peak current. To calculate the current in the worst case, use the minimum input voltage, maximum output voltage and maximum load current of application. In a boost regulator, the input DC current can be calculated as Equation 5.

$$I_{L(DC)} = \frac{V_{OUT} \times I_{OUT}}{V_{IN} \times \eta} \quad (5)$$

where:

V_{OUT} = boost output voltage

I_{OUT} = boost output current

V_{IN} = boost input voltage

η = power conversion efficiency

The inductor current peak-to-peak ripple can be calculated as Equation 6.

$$\Delta I_{L(P-P)} = \frac{1}{L \times \left(\frac{1}{V_{OUT} - V_{IN}} + \frac{1}{V_{IN}} \right) \times f_{SW}} \quad (6)$$

where:

$\Delta I_{L(P-P)}$ = inductor peak-to-peak ripple

L = inductor value

f_{SW} = boost switching frequency

V_{OUT} = boost output voltage

V_{IN} = boost input voltage

Therefore, the peak current $I_{L(P)}$ seen by the inductor is calculated with Equation 7.

$$I_{L(P)} = I_{L(DC)} + \frac{\Delta I_{L(P-P)}}{2} \quad (7)$$

Inductor values can have $\pm 20\%$ tolerance with no current bias. When the inductor current approaches saturation level, its inductance can decrease 20% to 35% from the 0A value depending on how the inductor vendor defines saturation current. Using an inductor with a smaller inductance value forces discontinuous PWM when the inductor current ramps down to zero before the end of each switching cycle. This reduces the boost converter's maximum output current, causes large input voltage ripple and reduces efficiency. Large inductance value provides much more output current and higher conversion efficiency. For these reasons, a 4.7 μ H to 22 μ H inductor value range is recommended, and a 4.7 μ H inductor is recommended for higher than 5V input voltage by considering inductor peak current and loop stability.

Schottky Diode Selection

The SGM3759 demands a low forward voltage, high-speed and low capacitance Schottky diode for optimum efficiency. Ensure that the diode average and peak current rating exceeds the average output current and peak inductor current. In addition, the diode reverse breakdown voltage must exceed the open LED protection voltage. NXP PMEG4030ER is recommended for the SGM3759.

APPLICATION INFORMATION (continued)

Output Capacitor Selection

The output capacitor is mainly selected to meet the requirement for the output ripple and loop stability. This ripple voltage is related to capacitor capacitance and its equivalent series resistance (ESR). Assuming a capacitor with zero ESR, the minimum capacitance needed for a given ripple can be calculated with Equation 8:

$$C_{OUT} = \frac{(V_{OUT} - V_{IN}) \times I_{OUT}}{V_{OUT} \times f_S \times V_{RIPPLE}} \quad (8)$$

where:

V_{RIPPLE} = peak-to-peak output ripple

The additional part of the ripple caused by ESR is calculated using: $V_{RIPPLE_ESR} = I_{OUT} \times R_{ESR}$.

Due to its low ESR, V_{RIPPLE_ESR} could be neglected for ceramic capacitors, and a 1µF to 10µF capacitor is recommended for typical application.

A 1µF output capacitor is suggested for 7S2P LED applications. For high output current applications like 3S20P, larger value output capacitors of 10µF is recommended to minimize the output ripple.

LED Current Set Resistor

The LED current set resistor can be calculated by Equation 1, where $V_{FB} = 200mV$. In addition, the rated power dissipation of the resistor should be considered when large current is needed.

Thermal Considerations

The allowable IC junction temperature should be considered under normal operating conditions. This restriction limits the power dissipation of the SGM3759. The allowable power dissipation for the device can be determined by Equation 9:

$$P_D = \frac{150^\circ C - T_A}{\theta_{JA}} \quad (9)$$

where:

T_A is the ambient temperature for the application.

θ_{JA} is the thermal resistance junction-to-ambient given in Power Dissipation Table.

Power Supply Recommendations

The device is designed to operate from an input voltage supply range between 2.7V and 5.5V. This input supply must be well regulated. If the input supply is located more than a few inches from the SGM3759 device, additional bulk capacitance may be required in addition to the ceramic bypass capacitors.

EMI Precaution and Ringing Cancelling

Careful layout, routing and selection of decoupling components are equal keys to successfully putting a high energy transmission swing boost backlight driver together with a waveform sensitive communication transceiver into a condensed case. Engineering test on cellular phones indicates, with separation and isolation from shielding case, that conducting propagation along the power supply trace contributes the most comparing with the other EMI mechanisms.

Ways of suppressing EMI include limiting of propagation and reduction of energy swings, such as inserting absorbing ferrite bead in power supply trace, selecting high self-resonance frequency decoupling capacitors and ringing cancellation. Figure 6 is a simplified circuit showing that ringing is relaxation oscillation between diode junction capacitance C_j and boost inductor L , which injects current swings into power supply trace; the two voltage waveforms illustrate the difference of circuit performance, with or without ringing cancellation.

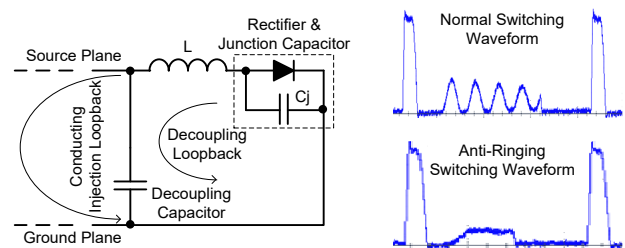

Figure 6. Ringing Cancellation Illustration

APPLICATION INFORMATION (continued)

Layout Considerations

As for all switching power supplies, especially those high frequency and high current ones, layout is an important design step. If layout is not carefully done, the regulator could suffer from instability as well as noise problems. Therefore, use wide and short traces for high current paths. The input capacitor C_{IN} needs to be close to VIN pin and GND pin in order to reduce the input ripple seen by the IC. If possible choose higher capacitance value for it. The SW pin carries high current with fast rising and falling edges, therefore, the

connection between the SW pin to the inductor should be kept as short and wide as possible. The output capacitor C_{OUT} should be put close to V_{OUT} . It is also beneficial to have the ground of C_{OUT} close to the GND pin since there is large ground return current flowing between them. FB resistor should be put close to FB pin. When laying out signal ground, it is recommended to use short traces separated from power ground traces, and connect them together at a single point close to the GND pin.

ADDITIONAL TYPICAL APPLICATION

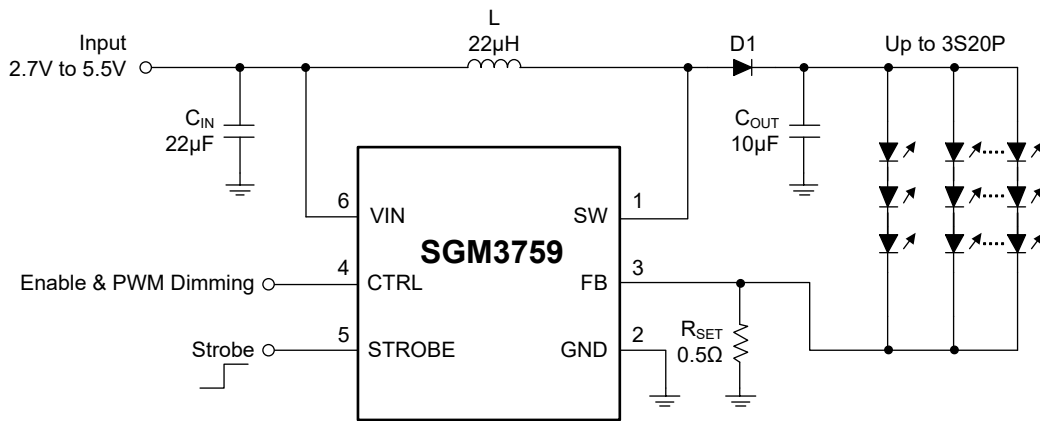

Figure 7. Drive 60 LEDs for Media Form Factor Display

REVISION HISTORY

NOTE: Page numbers for previous revisions may differ from page numbers in the current version.

Changes from Original (FEBRUARY 2018) to REV.A

Changed from product preview to production data.....	All
--	-----

PACKAGE INFORMATION

PACKAGE OUTLINE DIMENSIONS

TSOT-23-6

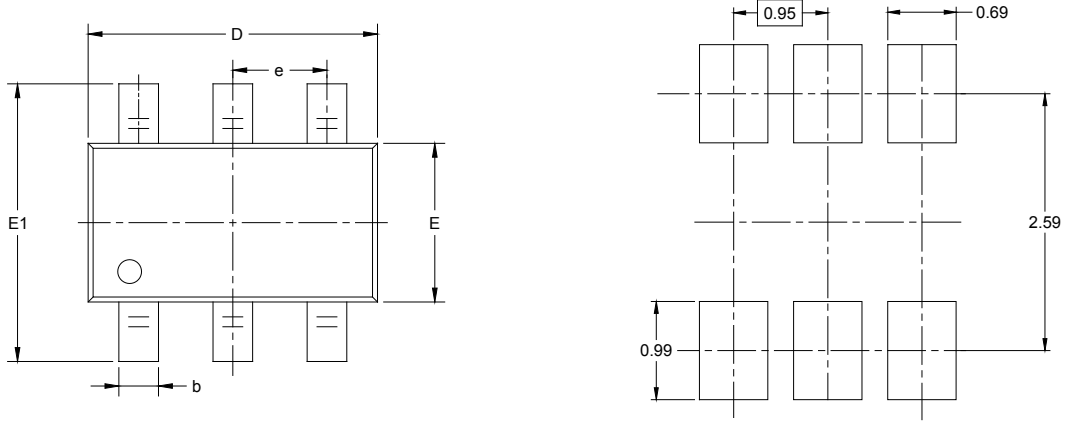

RECOMMENDED LAND PATTERN (Unit: mm)

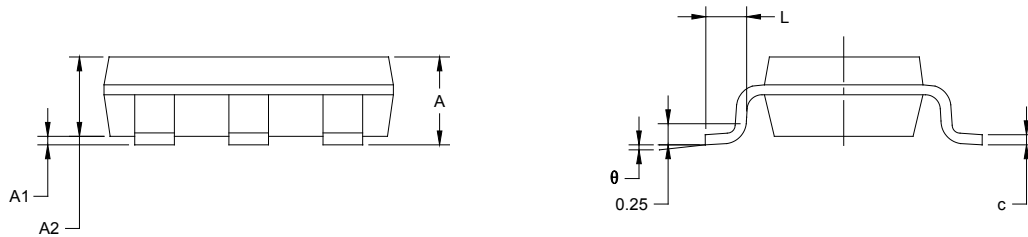

Symbol	Dimensions In Millimeters		Dimensions In Inches	
	MIN	MAX	MIN	MAX
A		1.000		0.043
A1	0.000	0.100	0.000	0.004
A2	0.700	0.900	0.028	0.039
b	0.300	0.500	0.012	0.020
c	0.080	0.200	0.003	0.008
D	2.850	2.950	0.112	0.116
E	1.550	1.650	0.061	0.065
E1	2.650	2.950	0.104	0.116
e	0.950 BSC		0.037 BSC	
L	0.300	0.600	0.012	0.024
θ	0°	8°	0°	8°

PACKAGE INFORMATION

TAPE AND REEL INFORMATION

REEL DIMENSIONS



TAPE DIMENSIONS



NOTE: The picture is only for reference. Please make the object as the standard.

KEY PARAMETER LIST OF TAPE AND REEL

Package Type	Reel Diameter	Reel Width W1 (mm)	A0 (mm)	B0 (mm)	K0 (mm)	P0 (mm)	P1 (mm)	P2 (mm)	W (mm)	Pin1 Quadrant
TSOT-23-6	7"	9.5	3.20	3.10	1.10	4.0	4.0	2.0	8.0	Q3

DD0001

PACKAGE INFORMATION

CARTON BOX DIMENSIONS



NOTE: The picture is only for reference. Please make the object as the standard.

KEY PARAMETER LIST OF CARTON BOX

Reel Type	Length (mm)	Width (mm)	Height (mm)	Pizza/Carton
7" (Option)	368	227	224	8
7"	442	410	224	18

DD0002