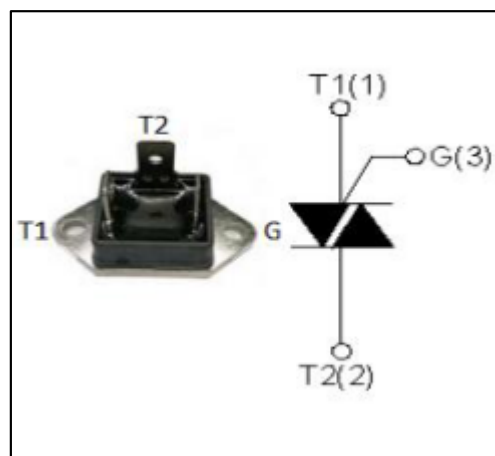

FEATURES

- Suitable for general purpose AC switching. They can be used as an ON/OFF function in applications such as static relays, heating regulation, induction motor starting circuits.
- Minimum Lot-to-Lot variations for robust device performance and reliable operation

ABSOLUTE MAXIMUM RATINGS(T_a=25°C)

SYMBOL	PARAMETER	MIN	UNIT
V _{DRM}	Repetitive peak off-state voltage	600	V
V _{RRM}	Repetitive peak reverse voltage	600	V
I _{T(RMS)}	RMS on-state current (full sine wave) T _j =95°C	40	A
I _{TSM}	Non-repetitive peak on-state current t _p =20ms	400	A
T _j	Operating junction temperature	-40~125	°C
T _{stg}	Storage temperature	-40~150	°C
P _{G(AV)}	Average gate power dissipation(T _j =125°C)	1	W
R _{th(j-c)}	Thermal resistance, junction to case	0.9	°C/W

ELECTRICAL CHARACTERISTICS (T_c=25°C unless otherwise specified)

SYMBOL	PARAMETER	CONDITIONS	B	C	UNIT	
I _{RRM}	Repetitive peak reverse current	V _R =V _{RRM} , V _R =V _{RRM} , T _j =125°C	0.01 2.0	0.01 2.0	mA	
I _{DRM}	Repetitive peak off-state current	V _D =V _{DRM} , V _D =V _{DRM} , T _j =125°C	0.01 2.0	0.01 2.0	mA	
I _{GT}	Gate trigger current	V _D =12V; R _L = 100 Ω	I	50	25	mA
			II	50	25	
			III	50	25	
			IV	100	50	
I _H	Holding current	I _{GT} = 0.5A, Gate Open	60	35	mA	
V _{GT}	Gate trigger voltage all quadrant	V _D =12V; R _L = 100 Ω	1.5		V	
V _{TM}	On-state voltage	I _T = 60A; t _p = 380 μs	1.55		V	

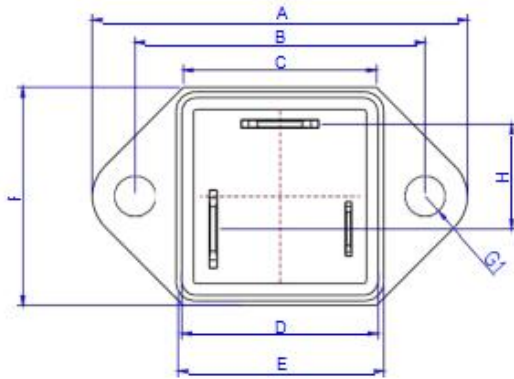

I

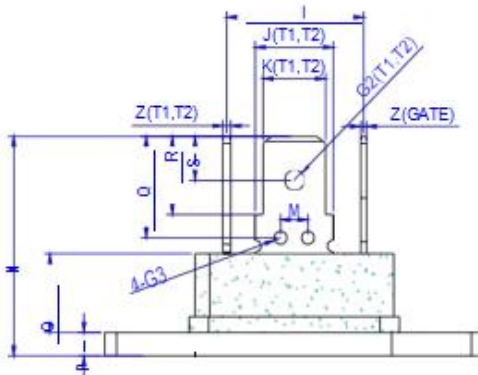

Ref.	尺寸					
	Millimeters毫米			Inches英寸		
	Min.	Typ.	Max.	Min.	Typ.	Max.
A			39.2			1.543
B	29.8	30.0	30.2	1.173	1.181	1.189
C			20.2			0.795
D			20.5			0.807
E			21.6			0.85
F			23			0.905
G1	Φ4.1	Φ4.2	Φ4.3	Φ0.161	Φ0.165	Φ0.169
H		10.3			0.406	
I		13.9			0.547	
J(T1,T2)		8			0.315	
K(T1,T2)		6.4			0.252	
M	2.7	3.0	3.3	0.106	0.118	0.130
N	22.4	22.6	22.8			0.898
O		8.2			0.323	
P		2.5			0.098	
Q	9.45	9.75	10.1	0.374	0.383	0.398
R	7.8	7.95	8.1	0.307	0.313	0.319
S	4.3	4.5	4.7	0.169	0.177	0.185
G2(T1,T2)		Φ3.8	Φ3.9		Φ0.079	Φ0.087
G3	Φ1.1	Φ1.3	Φ1.5	Φ0.043	Φ0.051	Φ0.059
G4		Φ1.55	Φ1.75		Φ0.061	Φ0.069
a	2.95	3.15	3.35	0.116	0.124	0.132
b	6.2	6.35	6.5	0.244	0.25	0.256
c	9.35	9.75	10	0.368	0.384	0.393
Z(GATE)	0.58	0.6	0.65	0.0228	0.0236	0.0256
J(GATE)		5.6			0.221	
K(GATE)		4.65			0.183	